

YKF 4" POMPA INTERNAL ECCENTRIC GEAR PUMP



POMPA DEĞERLERİ / PUMP PROPERTIES

Q	: 55 m ³ /h
Hm	:1 ~ 14 Bar
T	:0 ~ 200 °C
n	:400 d/d
Visc.	:22 ~ 55.000 cst

KULLANIM ALANLARI

- Fuel Oil Servis Tankları, Gaz Yağı, Mazot Tankerlerinde
- Reçine ve Polimerler
- Asfalt ve Bitüm
- Kağıt ve Boya Sanayinde
- Küçük çapta kızgın yağ sirkülasyonlarında
- İlaç, kimya ve deterjan sanayinde
- Gıda Sanayinde.

USE AREAS

- Fuel Oil Service Tanks, Gasoil, Diesel Tankers
- Resin and Polymer
- Asphalt and Bitumen
- Paper and Paint/dye industry
- Circulation of Hot Oil (limited)
- Medicine, Chemical and Detergent Industry
- Food Industry.

MALZEME SEÇENEKLERİ

- Pompa Gövdesi, Kapaklar : Dökme (pik) demir, Sfero döküm, Çelik döküm, Paslanmaz AISI 304- AISI 316 döküm
- Dişliler : Sfero döküm, Çelik döküm, Paslanmaz AISI 304- AISI 316 döküm
- Yataklar : Snbz 12 bronz, karbon grafit, Silisyum Karbür, Sert Metal Kaplama, rulman
- Sızdırmazlık: Yumuşak Salmastra, Rotatherm Salmastra, Mekanik salmastra. Keçeli Sistem, Kartex Mekanik Salmastra

MATERIAL OPTIONS

- Pump Body, covers : Pig Cast Iron, Spheroidal Cast iron, Cast Steel, AISI 304/316 CrNi Stainless Steel
- Gears : Spheroidal Cast iron, Cast Steel, AISI 304/316 CrNi Stainless Steel
- Bearings: Snbz 12 bronze, carbon graphite, silicon carbide, hard metal coated steel, bearing
- Sealing: Soft Seal or Packing Gland, Rotatherm Seal, Lip Seal, Mechanical Seal, Cartridge Type Mechanical Seal

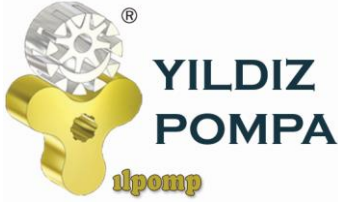

YKF 4" POMPA INTERNAL ECCENTRIC GEAR PUMP



İÇTEN EKSANTİK DİŞLİ POMPA ÇALIŞMA PRENSİBİ / WORKING PRINCIPLE OF INTERNAL ECCENTRIC GEAR PUMP

Yıldız Pompa' nın "dişli içinde dişli" prensibinde sadece iki tane hareketli parça vardır. Bütün pozitif deplasmanlı YILDIZ dişli pompalarının güvenilir ve verimli çalışmasının sırrı budur. Sıvının pozitif deplasmanı (yer değiştirmesi) rotor ve avare dişlisinin dişleri arasındaki boşluğun komple dolmasıyla sağlanmaktadır. Bütün dişli pompalarda olduğu gibi, YILDIZ POMPA' da da performansın en üst noktaya çıkmasını sınırlayıcı yegane faktör, pompalanan sıvının diğerlerine göre daha temiz olmasını istemesidir.

Pompa milinin her devrinde emiş ağızı yoluyla belli bir miktar sıvı pompaya girer. Bu sıvı rotor ile avare dişlisi arasındaki boşluğu doldurur. Pompa kapağında bulunan hilal, çıkış ağızına doğru pürüzsüz şekilde hareket eden sıvının akışını ayırır. Kendi dişleri ile hilalin iç yüzeyi arasında sıvı taşıyan avare dişlisi pompa kapağının desteklediği bir mil üzerinde döner. Dişleri arasında sıvı taşıyan rotor dişlisi pompa gövdesi ile hilalin dış yüzeyi arasında hareket eder ve pompa miline bağlıdır.

YILDIZ's simple "gear-within a gear" principle has only two moving parts. It is the secret of dependable, efficient operation of all positive displacement YILDIZ POMPA's PUMPS. The positive displacement of liquid is accomplished by the complete filling of the spaces between the teeth of the rotor and idler gears. The only limiting factor to peak performance in YILDIZ POMPA, as with all rotary pumps, is that the liquid pumped must be comparatively clean.

With every revolution of the pump's shaft, a definite amount of liquid enters the pump through the suction port. This liquid fills the spaces between the teeth of the rotor and the idler. The crescent on the pump head splits the flow of liquid as it moves smoothly towards the discharge port. The idler gear, which carries the liquid between its teeth and the inside surface of the crescent is connected to pump cover. On the otherhand, rotor gear which is rotated directly with pump shaft delivers the liquid between gear teeth and crescent's souter surface.

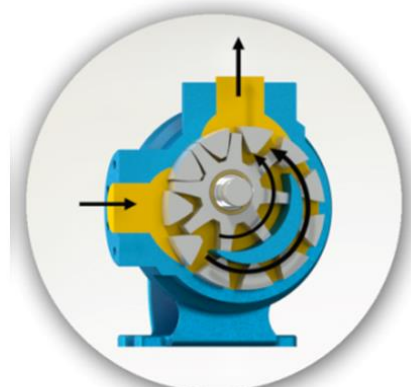
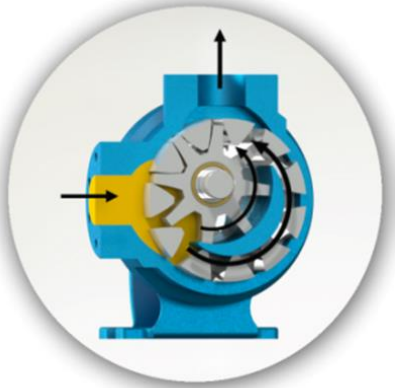

YKF 4" POMPA INTERNAL ECCENTRIC GEAR PUMP

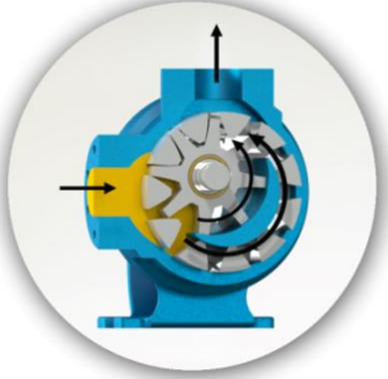

Yandaki renkli kısım sıvının pompa gövdesindeki emiş ağızı alanına, rotor dişlisi ve avare dişlisi dişleri arasındaki dişli boşlukları alanına girişini gösterir. İki siyah ok pompanın dönüş ve sıvının ilerleyişini gösterir.

The yellow colored portion at side indicates the liquid as it enters the suction port area of the casing and the area between the rotor teeth and corresponding concave area between the idler teeth. The two black arrows indicate the pump rotation and progress of the liquid.



"Dişli içinde dişli" prensibinde çalışan dişliler ile pompa içinde sıvının ilerleyişine dikkat edin. Aynı zamanda, pompa kapağı üzerindeki hilal şeklinin sıvıyı nasıl böldüğüne ve emiş ile boşaltma ağızları arasında bir keçe (conta) gibi vazife gördüğüne dikkat ediniz.

Notice the progress of the liquid through the pump and between the teeth of rotor idler gear. Also, note how the crescent shape on the head divides the liquid and acts as a seal between the suction and discharge ports.

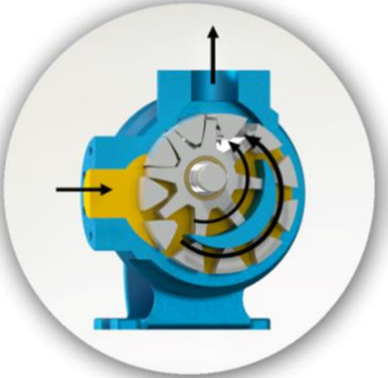

Bu resim pompanın iç kısmının dolup sıvının boşaltma ağızı alanına itilmesinden hemen önceki durumunu göstermektedir. Avare ve rotor dişlilerinin dizaynının sıvı için nasıl bir kapalı cep oluşturduğuna ve bunun tam bir hacim kontrolü sağlanmasını nasıl garantilediğine dikkat ediniz.

This illustration shows the pump in a nearly flooded condition just previous to the liquid being forced into the discharge port area. Notice how the gear design of the idler and rotor form locked pockets for the liquid to guarantee absolute volume control.



Bu görüntü pompanın tamamen dolup taşıdığı durumu ve sıvının boşaltma işlemini, boşaltma ağızından ilerleyişini göstermektedir. Emiş ve boşaltma ağızlarına eşit mesafede sızdırmaz bir keçe oluşturan, sıvıyı boşaltma ağızından dışarı doğru iten, rotor ve avare dişlisinin dişleri birbiri içine geçer.

The view shows the pump in a completely flooded condition and in the process of discharging the liquid through discharge port. The rotor and idler teeth mesh, forming a seal equidistant between the both ports, forcing liquid out the discharge port.



YKF 4" POMPA INTERNAL ECCENTRIC GEAR PUMP



YKF-4" POMPASINA AİT KAPASİTE VE GÜÇ TABLOSU /
CAPACITY AND POWER TABLE

KAPASİTE (m ³ /h) CAPACITY (Q)	DEVİR (d/d) SPEED (rpm)	ÇIKIŞ BASINCI / PRESSURE				VİSKOZİTE VISCOSITY
		2,5 Bar	5 Bar	7,5 Bar	10 Bar	
8	60	4 kw	4 kw	5.5 kw	5.5 kw	16.500 est
10	80	5.5 kw	5.5 kw	7.5 kw	7.5 kw	5.500 est
12	100	5.5 kw	7.5 kw	7.5 kw	7.5 kw	5.500 est
34	250	11 kw	15 kw	18.5 kw	22 kw	5.500 est
42	300	11 kw	15 kw	18.5 kw	22 kw	5.500 est
50	350	11 kw	15 kw	18.5 kw	22 kw	1.650 est
55	400	11 kw	15 kw	18.5 kw	22 kw	550 est

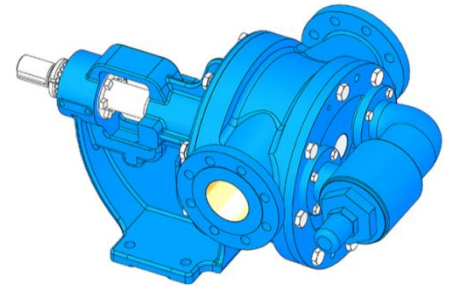
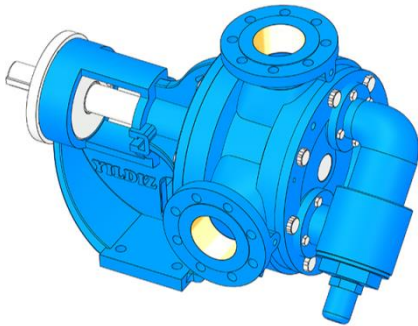
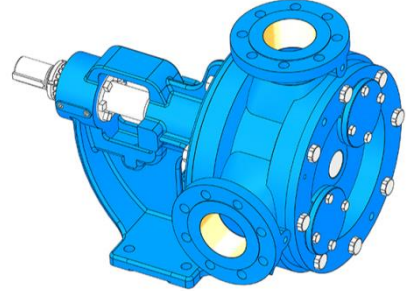
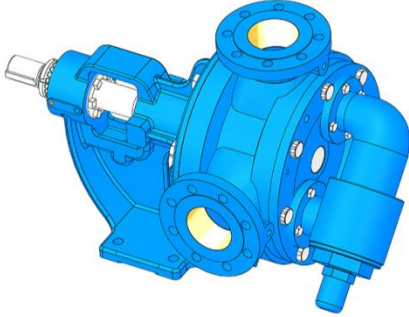
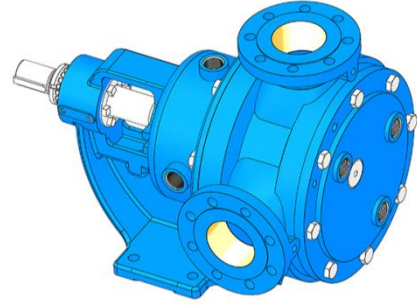
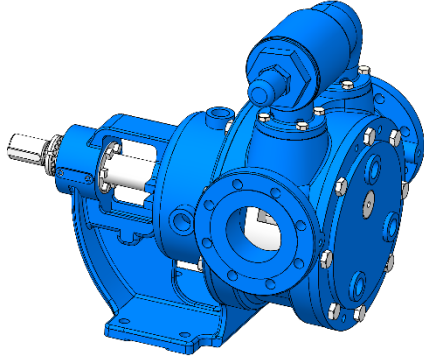



KAPASİTE EĞRİLERİ / CAPACITY GRAPHS

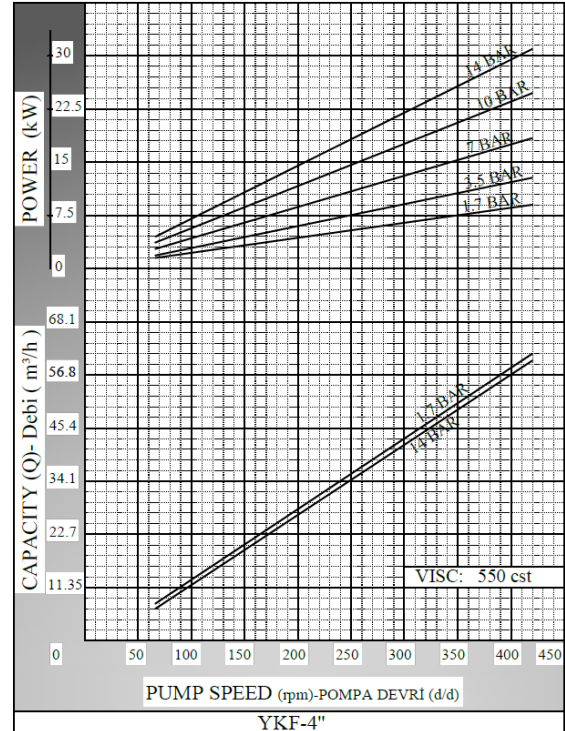
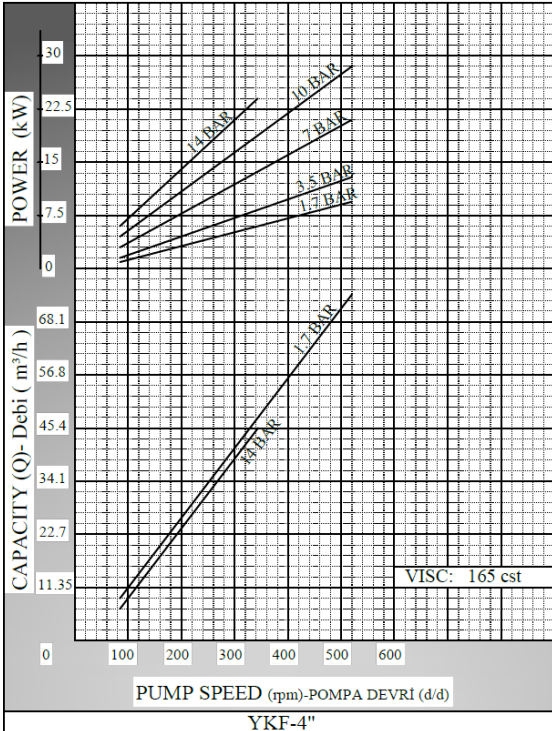
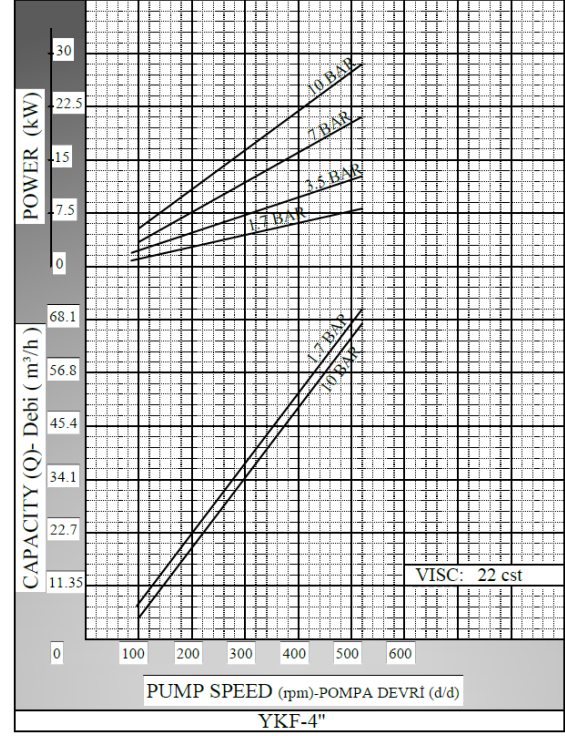
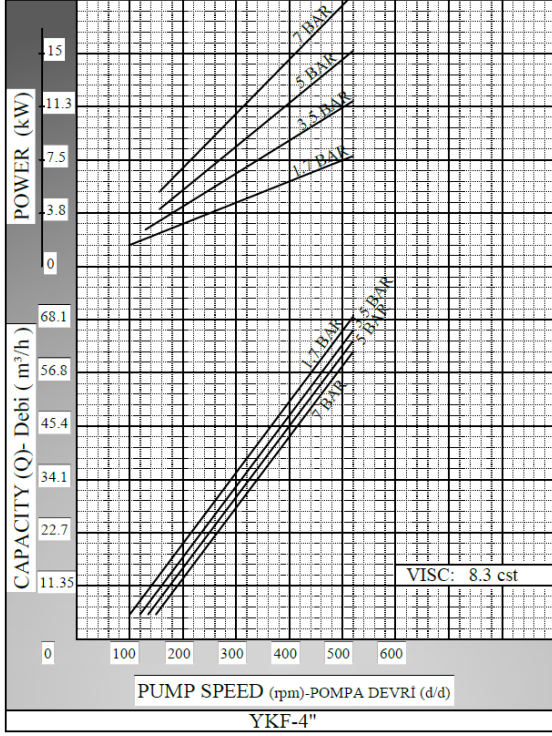

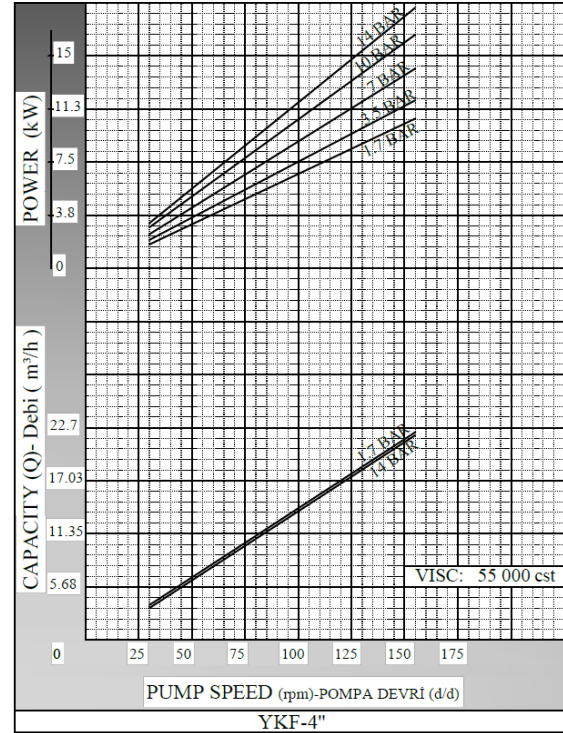
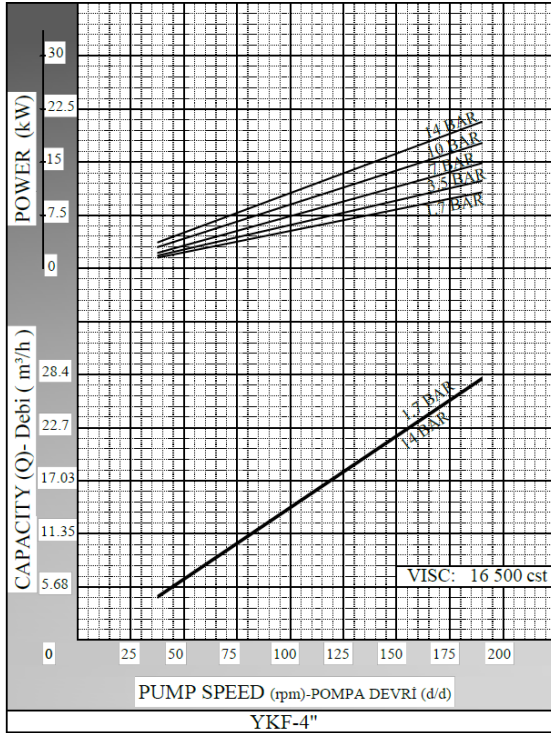
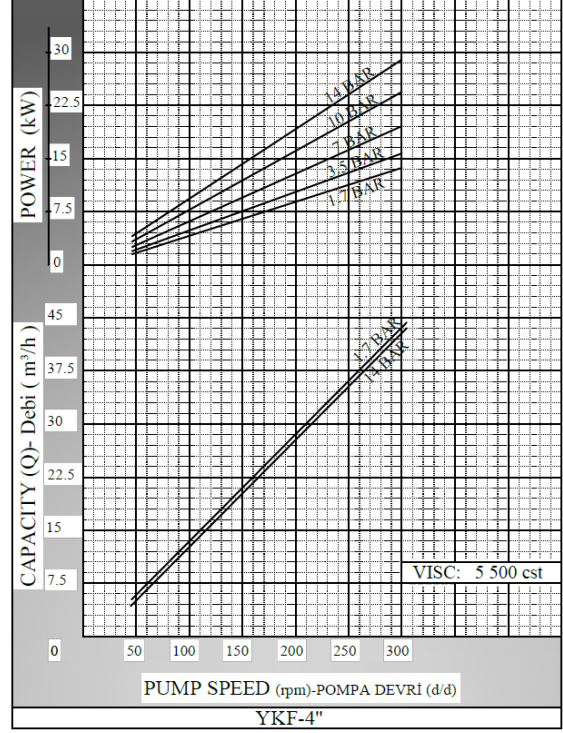
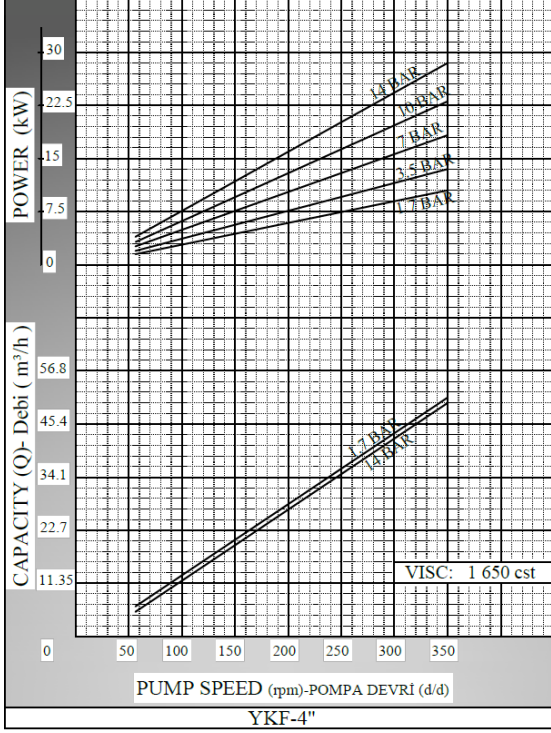



**YILDIZ
POMPA**

ilpomp

**YKF 4" POMPA
INTERNAL ECCENTRIC
GEAR PUMP**



POMPA BOYUT ÖLÇÜLERİ / PUMP DIMENSIONS

YKF 4"

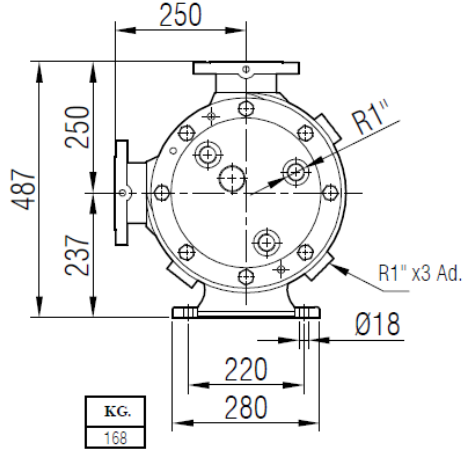

YKF 4"

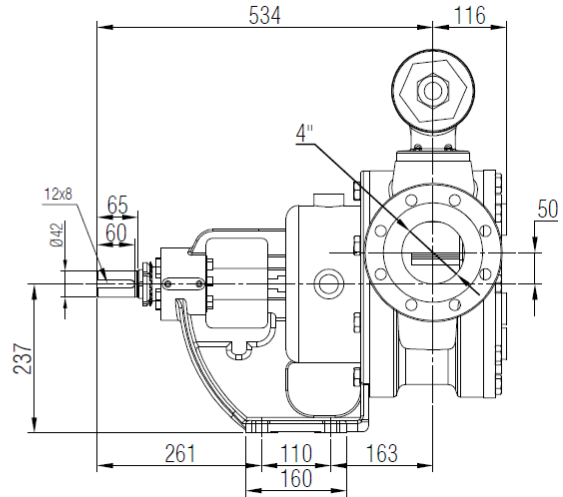
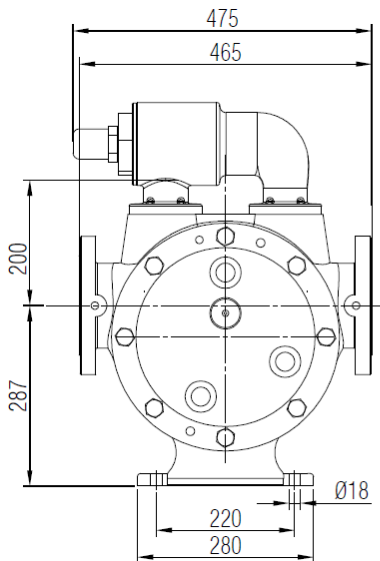
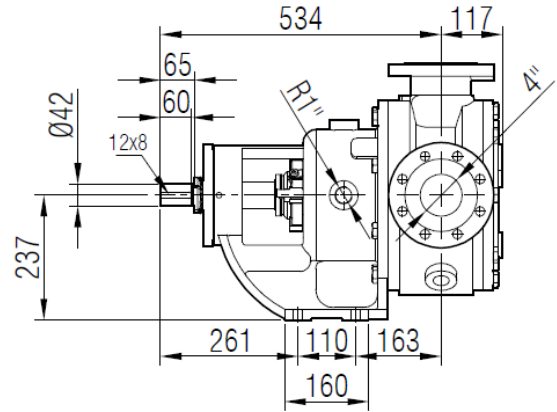
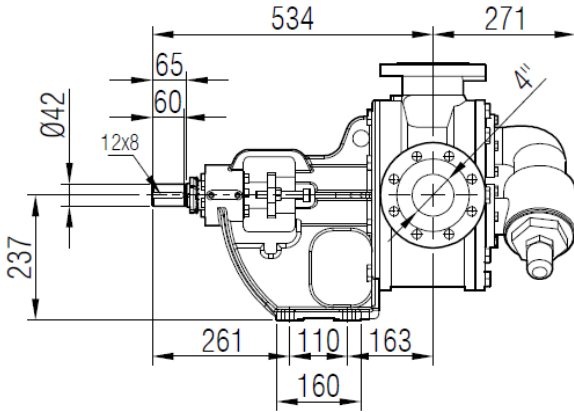
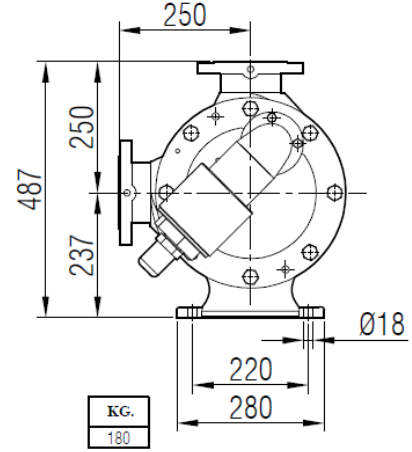



**YILDIZ
POMPA**

ilpomp

**YKF 4" POMPA
INTERNAL ECCENTRIC
GEAR PUMP**



**AKUPLAJ ÖLÇÜLERİ / COUPLING DIMENSIONS
REDÜKTÖR AKUPELİ / GEARBOX DRIVE**

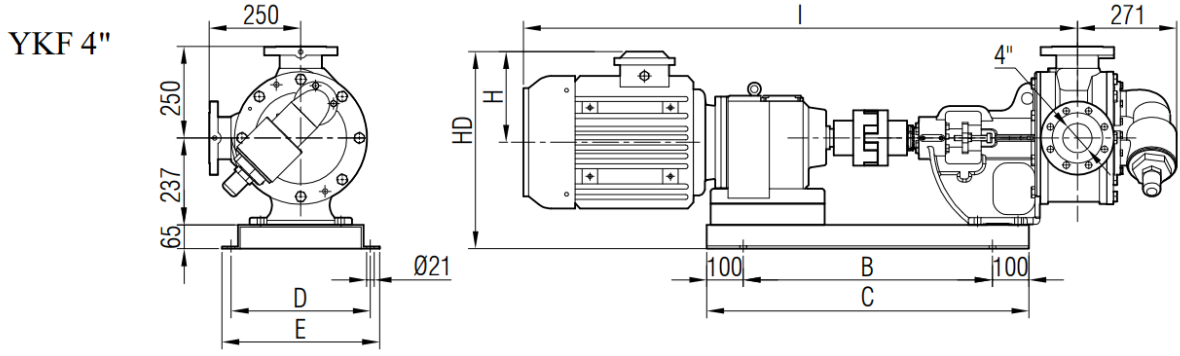

MOTOR GÜÇ VE DEVİRLERİ / MOTOR POWER AND SPEED			I	HD	H	B	C	D	E	F	kg.
15 hp / 11 kw	200/460 d/d (rpm)	İRAM72/132M	1383	468	182	680	880	390	430	237	320
20 hp / 15 kw	130/400 d/d (rpm)	İRAM82/160L	1601	503	225	830	1030	450	490		460
25 hp / 18,5 kw	159/400 d/d (rpm)	İRAM82/180M	1615	520	241						480
30 hp / 22 kw	130/350 d/d (rpm)	İRAM92/180L	1723	522	241	532					
40 hp / 30 kw	90/350 d/d (rpm)	İRAM102/200L	1911	569	275	950	1150	530	570		671

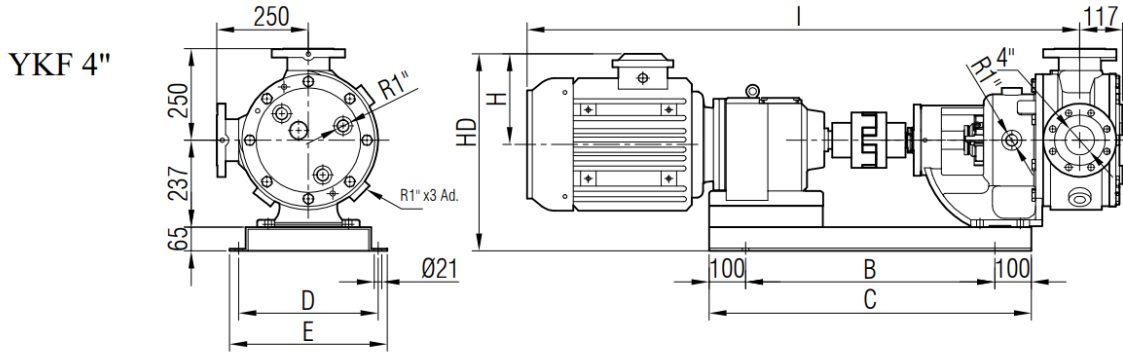

MOTOR GÜÇ VE DEVİRLERİ / MOTOR POWER AND SPEED			I	HD	H	B	C	D	E	F	kg.
5,5 hp / 4 kw	55/95 d/d (rpm)	İRAM73/132S	1337	468	182	680	880	390	430	237	294
7,5 hp / 5,5 kw	75/95 d/d (rpm)	İRAM73/132S	1222	435	149						307
10 hp / 7,5 kw	93/104 d/d (rpm)	İRAM73/132M	1383	468	182	318					
10 hp / 7,5 kw	57/91 d/d (rpm)	İRAM83/132M	1390	460	830	1030	450	490	362		
15 hp / 11 kw	40/57 d/d (rpm)	İRAM93/160M	1542	505					225		474

Not: Tüm ölçüler mm'dir. Flanşlar PN16'dır. / All dimensions are mm. Flanges are PN16.

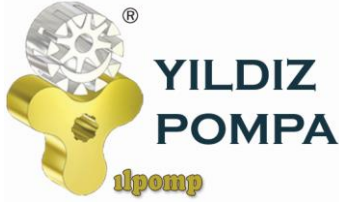

YK4 4" POMPA INTERNAL ECCENTRIC GEAR PUMP



YEDEK PARÇA LİSTESİ / SPARE PARTS LIST

YUMUŞAK SALMASTRALI VE BYPASSLI / SEALED WITH SOFT SEAL AND PRESSURE RELIEF
VALVE ON COVER

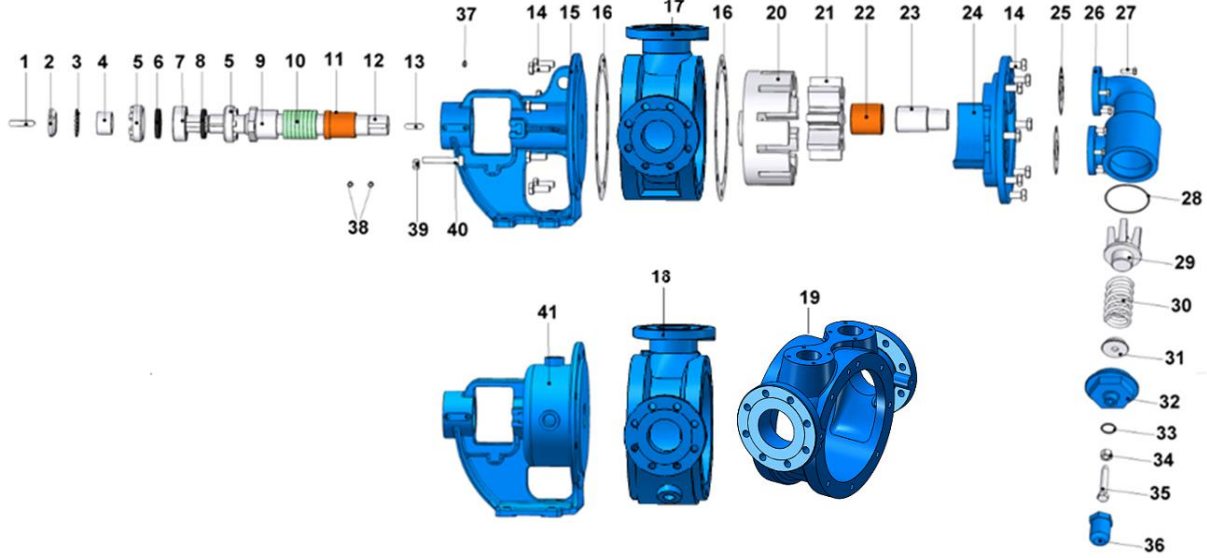

No	PARÇA İSMİ	PART NAME	ADET/ QTY.	No	PARÇA İSMİ	PART NAME	ADET/ QTY.
1	KAMA 12x8x60 AB	COUPLING KEY 12x8x60 AB	1	22	AVARA DIŞLİ BURCU	IDLER BUSHING	1
2	KİLİT SOMUNU	LOCK NUT	1	23	KAPAK MİLİ	COVER PIN	1
3	KİLİT SACI	LOCK WASHER	1	24	KAPAK (KÖR ve BYPASSLI)	COVER	1
4	BİLEZİK	SPACER	1	25	BYPASS CONTASI	BYPASS GASKET	2
5	AYAR SOMUNU	ADJUSTING NUT	2	26	BYPASS	PRESSURE RELIEF VALVE - BYPASS	1
6	KEÇE $\phi 55 \times \phi 72 \times 10$	LIP SEAL $\phi 55 \times \phi 72 \times 10$	1	27	6 KÖŞE CİVATA M10x30	HEX BOLT M10x30	8
7	RULMAN (3209)	BALL BEARING (3209)	1	28	BYPASS O-RİNG	BYPASS O-RING	1
8	KEÇE $\phi 50 \times \phi 72 \times 10$	LIP SEAL $\phi 50 \times \phi 72 \times 10$	1	29	KLEPE	VALVE	1
9	SALMASTRA BASKISI	PACKING PRESS	1	30	YAY	SPRING	1
10	YUMUŞAK SALMASTRA	SOFT SEAL / PACKING GLAND	1 TK.	31	PUL	WASHER	1
11	KONSOL BURCU	BRACKET BUSHING	1	32	BYPASS KAPAĞI	BYPASS COVER	1
12	MİL	SHAFT	1	33	TİJ KAPAK O-RİNG	CAP O-RING	1
13	KAMA 12x8x45 A	ROTOR KEY 12x8x45 A	1	34	M16 SOMUN	NUT M16	1
14	6 KÖŞE CİVATA M16x40	HEX BOLT M16x40	16	35	6 KÖŞE CİVATA M16x90	ADJUSTING SCREW M16x90	1
15	KONSOL	BRACKET	1	36	TİJ KAPAĞI	CAP	1
16	KONSOL & KAPAK CONTASI	BRACKET & COVER GASKET	2	37	GRESÖR R3/8"	GREASING FITTING R3/8"	1
17	ARA GÖVDE (FLANŞLI 90°)	CASING (w/ 90° FLANGED PORTS)	1	38	SETUSKUR M12x16	GRUB SCREW M12x16	4
18	ARA GÖVDE (FLANŞLI CEKETLİ 90°)	CASING (90° FLANGED & w/ HEATING JACKET)	1	39	M16 SOMUN	NUT M16	2
19	ARA GÖVDE (FLANŞLI 180°)	CASING (w/ 180° FLANGED PORTS)	1	40	4 KÖŞE SALMASTRA BASKI CİVATASI M16x90	SQUARE SCREW M16x90	2
20	ÇEVRE DIŞLİ	ROTOR GEAR	1	41	KONSOL (CEKETLİ)	BRACKET (w/ HEATING JACKET)	1
21	AVARA DIŞLİ	IDLER GEAR	1				



YKF 4" POMPA INTERNAL ECCENTRIC GEAR PUMP



YEDEK PARÇA LİSTESİ / SPARE PARTS LIST

YUMUŞAK SALMASTRALI, CEKETLİ VE KÖR KAPAKLI / SEALED WITH SOFT SEAL, JACKETED,
AND WITH BLIND COVER

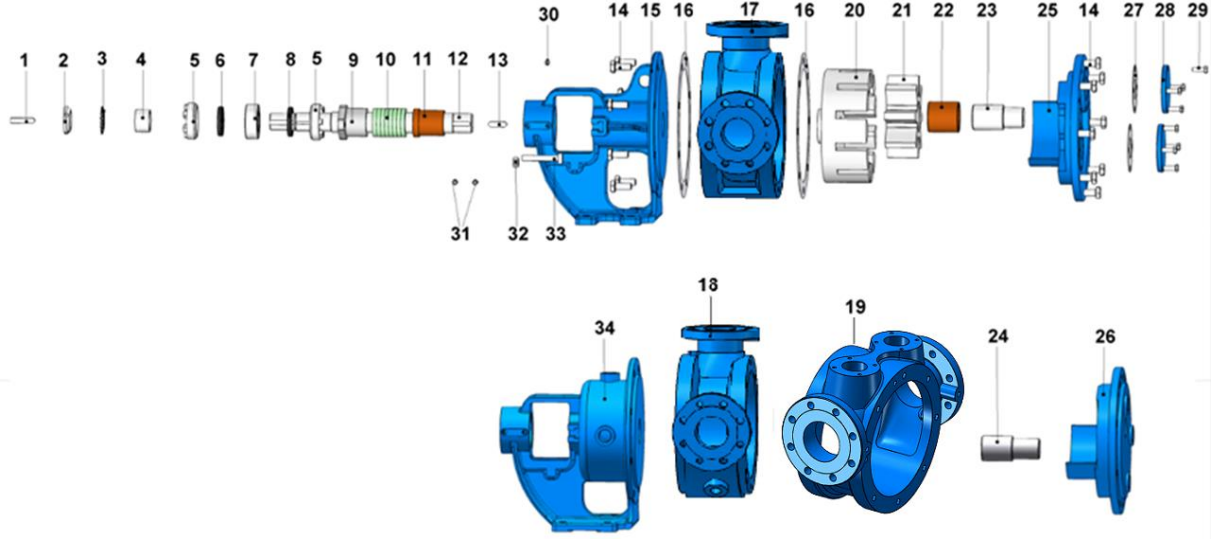

No	PARÇA İSMİ	PART NAME	ADET/ QTY.	No	PARÇA İSMİ	PART NAME	ADET/ QTY.
1	KAMA 12x8x60 AB	COUPLING KEY 12x8x60 AB	1	18	ARA GÖVDE (FLANŞLI CEKETLİ 90°)	CASING (90° FLANGED & w/ HEATING JACKET)	1
2	KİLİT SOMUNU	LOCK NUT	1	19	ARA GÖVDE (FLANŞLI 180°)	CASING (w/ 180° FLANGED PORTS)	1
3	KİLİT SACI	LOCK WASHER	1	20	ÇEVRE DİŞLİ	ROTOR GEAR	1
4	BİLEZİK	SPACER	1	21	AVARA DİŞLİ	IDLER GEAR	1
5	AYAR SOMUNU	ADJUSTING NUT	2	22	AVARA DİŞLİ BURCU	IDLER BUSHING	1
6	KEÇE $\phi 55 \times \phi 72 \times 10$	LIP SEAL $\phi 55 \times \phi 72 \times 10$	1	23	KAPAK MİLİ	COVER PIN	1
7	RULMAN (3209)	BALL BEARING (3209)	1	24	CEKETLİ KAPAK MİLİ	JACKETD COVER PIN	1
8	KEÇE $\phi 50 \times \phi 72 \times 10$	LIP SEAL $\phi 50 \times \phi 72 \times 10$	1	25	KAPAK (KÖR ve BYPASSLI)	COVER	1
9	SALMASTRA BASKISI	PACKING PRESS	1	26	KAPAK (CEKETLİ)	JACKETD COVER	1
10	YUMUŞAK SALMASTRA	SOFT SEAL / PACKING GLAND	1 TK.	27	BYPASS CONTASI	BYPASS GASKET	2
11	KONSOL BURCU	BRACKET BUSHING	1	28	BYPASS KÖR KAPAK	BYPASS INLETS COVER	2
12	MİL	SHAFT	1	29	6 KÖŞE CİVATA M10x30	HEX BOLT M10x30	8
13	KAMA 12x8x45 A	ROTOR KEY 12x8x45 A	1	30	GRESÖR R3/8"	GREASING FITTING R3/8"	1
14	6 KÖŞE CİVATA M16x40	HEX BOLT M16x40	16	31	SETUSKUR M12x16	GRUB SCREW M12x16	4
15	KONSOL	BRACKET	1	32	M16 SOMUN	NUT M16	2
16	KONSOL & KAPAK CONTASI	BRACKET & COVER GASKET	2	33	4 KÖŞE SALMASTRA BASKI CİVATASI M16x90	SQUARE SCREW M16x90	2
17	ARA GÖVDE (FLANŞLI 90°)	CASING (w/ 90° FLANGED PORTS)	1	34	KONSOL (CEKETLİ)	BRACKET (w/ HEATING JACKET)	1

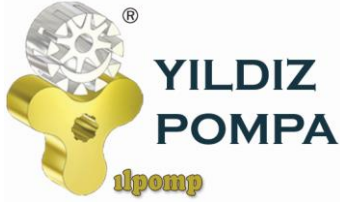

YKF 4" POMPA INTERNAL ECCENTRIC GEAR PUMP



YEDEK PARÇA LİSTESİ / SPARE PARTS LIST

MEKANİK SALMASTRALI VE BYPASSLI / SEALED WITH MECHANICAL SEAL, AND PRESSURE RELIEF VALVE ON COVER

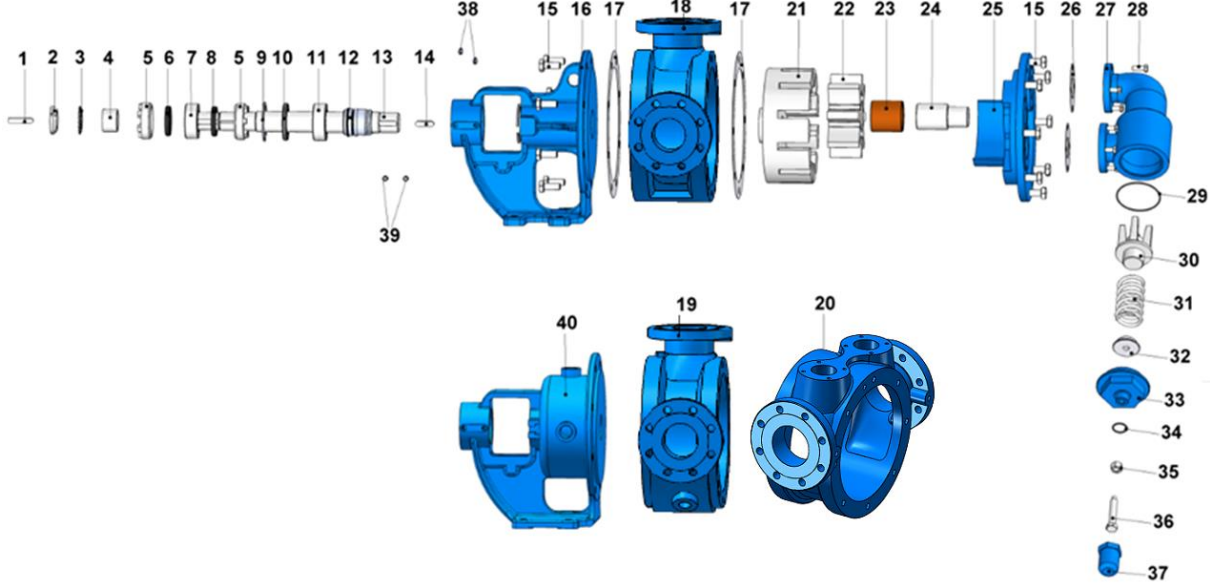

No	PARÇA İSMİ	PART NAME	ADET/ QTY.	No	PARÇA İSMİ	PART NAME	ADET/ QTY.
1	KAMA 12x8x60 AB	COUPLING KEY 12x8x60 AB	1	21	ÇEVRE DİŞLİ	ROTOR GEAR	1
2	KİLİT SOMUNU	LOCK NUT	1	22	AVARA DİŞLİ	IDLER GEAR	1
3	KİLİT SACI	LOCK WASHER	1	23	AVARA DİŞLİ BURCU	IDLER BUSHING	1
4	BİLEZİK	SPACER	1	24	KAPAK MİLİ	COVER PIN	1
5	AYAR SOMUNU	ADJUSTING NUT	2	25	KAPAK (KÖR ve BYPASSLI)	COVER	1
6	KEÇE $\phi 55 \times \phi 72 \times 10$	LIP SEAL $\phi 55 \times \phi 72 \times 10$	1	26	BYPASS CONTASI	BYPASS GASKET	2
7	RULMAN (3209)	BALL BEARING (3209)	1	27	BYPASS	PRESSURE RELIEF VALVE - BYPASS	1
8	KEÇE $\phi 50 \times \phi 72 \times 10$	LIP SEAL $\phi 50 \times \phi 72 \times 10$	1	28	6 KÖŞE CİVATA M10x30	HEX BOLT M10x30	8
9	İÇ SEGMAN ($\phi 90$)	INTERNAL CIRCLIP ($\phi 90$)	1	29	BYPASS O-RING	BYPASS O-RING	1
10	KEÇE $\phi 50 \times \phi 90 \times 10$	LIP SEAL $\phi 50 \times \phi 90 \times 10$	1	30	KLEPE	VALVE	1
11	RULMAN (3210)	BEARING (3210)	1	31	YAY	SPRING	1
12	MEKANİK SALMASTRA $\phi 50$	MECHANICAL SEAL $\phi 50$	1	32	PUL	WASHER	1
13	MİL	SHAFT	1	33	BYPASS KAPAĞI	BYPASS COVER	1
14	KAMA 12x8x45 A	ROTOR KEY 12x8x45 A	1	34	TİJ KAPAK O-RİNG	CAP O-RING	1
15	6 KÖŞE CİVATA M16x40	HEX BOLT M16x40	16	35	M16 SOMUN	NUT M16	1
16	KONSOL (AYAR SOMUNLU M. SALMASTRALI)	BRACKET (w/ ADJUSTING NUT AND MECHANICAL SEAL)	1	36	6 KÖŞE CİVATA M16x70	ADJUSTING SCREW M16x70	1
17	KONSOL & KAPAK CONTASI	BRACKET & COVER GASKET	2	37	TİJ KAPAĞI	CAP	1
18	ARA GÖVDE (FLANŞLI 90°)	CASING	1	38	GRESÖR R3/8"	GREASING FITTING R3/8"	2
19	ARA GÖVDE (FLANŞLI CEKETLİ 90°)	CASING (90° FLANGED & w/ HEATING JACKET)	1	39	SETUSKUR M12x16	GRUB SCREW M12x16	4
20	ARA GÖVDE (FLANŞLI 180°)	CASING (w/ 180° FLANGED PORTS)	1	40	KONSOL (CEKETLİ)	BRACKET (w/ HEATING JACKET)	1



YEDEK PARÇA LİSTESİ / SPARE PARTS LIST
**MEKANİK SALMASTRALI, CEKETLİ VE KÖR KAPAKLI / SEALED WITH
MECHANICAL SEAL, JACKETED, AND WITH BLIND COVER**

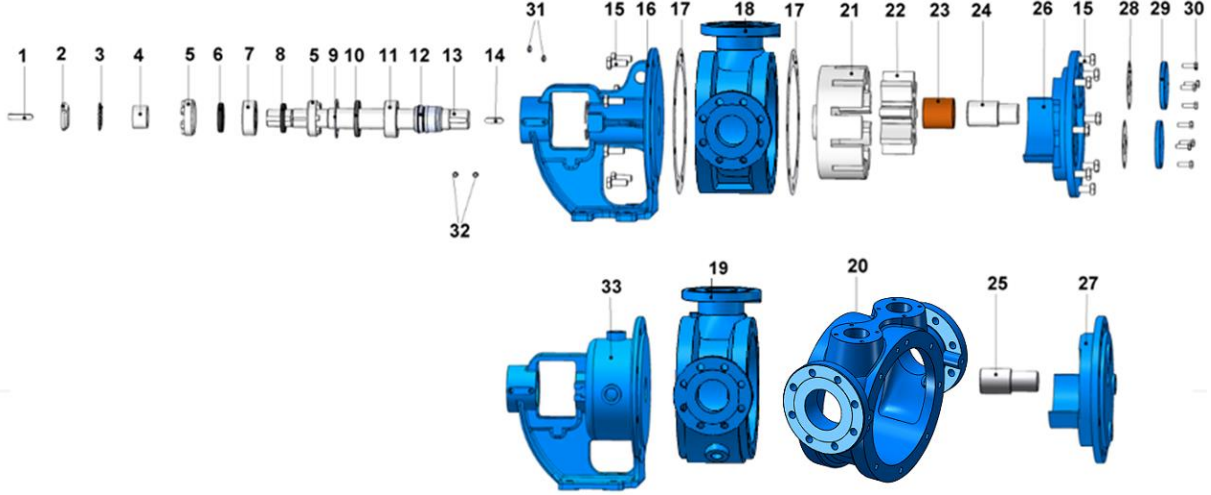

No	PARÇA İSMİ	PART NAME	ADET/ QTY.	No	PARÇA İSMİ	PART NAME	ADET/ QTY.
1	KAMA 12x8x60 AB	COUPLING KEY 12x8x60 AB	1	18	ARA GÖVDE (FLANŞLI 90°)	CASING (w/ 90° FLANGED PORTS)	1
2	KİLİT SOMUNU	LOCK NUT	1	19	ARA GÖVDE (FLANŞLI CEKETLİ 90°)	CASING (90° FLANGED & w/ HEATING JACKET)	1
3	KİLİT SACI	LOCK WASHER	1	20	ARA GÖVDE (FLANŞLI 180°)	CASING (w/ 180° FLANGED PORTS)	1
4	BİLEZİK	SPACER	1	21	ÇEVRE DİŞLİ	ROTOR GEAR	1
5	AYAR SOMUNU	ADJUSTING NUT	2	22	AVARA DİŞLİ	IDLER GEAR	1
6	KEÇE Ø55xØ72x10	LIP SEAL Ø55xØ72x10	1	23	AVARA DİŞLİ BURCU	IDLER BUSHING	1
7	RULMAN (3209)	BALL BEARING (3209)	1	24	KAPAK MİLİ	COVER PIN	1
8	KEÇE Ø50xØ72x10	LIP SEAL Ø50xØ72x10	1	25	KAPAK MİLİ	JACKETD COVER PIN	1
9	İÇ SEGMAN (Ø90)	INTERNAL CIRCLIP (Ø90)	1	26	KAPAK (KÖR ve BYPASSLI)	COVER	1
10	KEÇE Ø50xØ90x10	LIP SEAL Ø50xØ90x10	1	27	KAPAK (CEKETLİ)	JACKETD COVER	1
11	RULMAN (3210)	BEARING (3210)	1	28	BYPASS CONTASI	BYPASS GASKET	2
12	MEKANİK SALMASTRA Ø50	MECHANICAL SEAL Ø50	1	29	BYPASS KÖR KAPAK	BYPASS INLETS COVER	2
13	MİL	SHAFT	1	30	6 KÖŞE CİVATA M10x30	HEX BOLT M10x30	8
14	KAMA 12x8x45 A	ROTOR KEY 12x8x45 A	1	31	GRESÖR R3/8"	GREASING FITTING R3/8"	2
15	6 KÖŞE CİVATA M16x40	HEX BOLT M16x40	16	32	SETUSKUR M12x16	GRUB SCREW M12x16	4
16	KONSOL	BRACKET	1	33	KONSOL (CEKETLİ)	BRACKET (w/ HEATING JACKET)	1
17	KONSOL & KAPAK CONTASI	BRACKET & COVER GASKET	2				



YKF 4" POMPA INTERNAL ECCENTRIC GEAR PUMP



YEDEK PARÇA LİSTESİ / SPARE PARTS LIST KEÇELİ, CEKETLİ VE KÖR KAPAKLI / SEALED WITH LIP SEAL, JACKETED AND WITH BLIND COVER

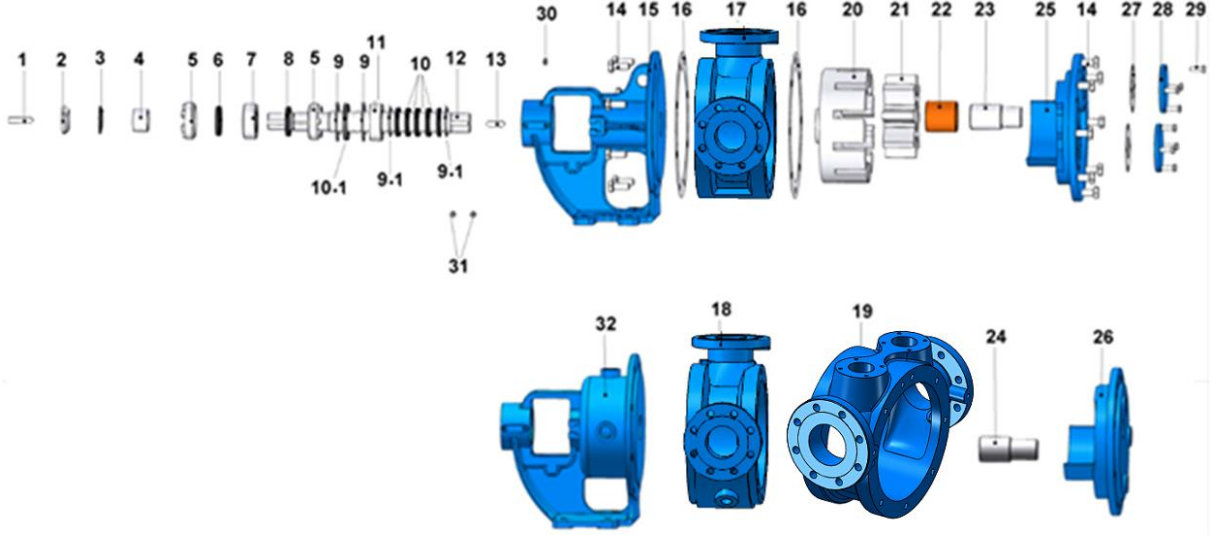

No	PARÇA İSMİ	PART NAME	ADET/ QTY.	No	PARÇA İSMİ	PART NAME	ADET/ QTY.
1	KAMA12x8x60 AB	COUPLING KEY 12x8x60 AB	1	17	ARA GÖVDE (FLANŞLI 90°)	CASING (w/ 90° FLANGED PORTS)	1
2	KİLİT SOMUNU	LOCK NUT	1	18	ARA GÖVDE (FLANŞLI CEKETLİ 90°)	CASING (90° FLANGED & w/ HEATING JACKET)	1
3	KİLİT SACI	LOCK WASHER	1	19	ARA GÖVDE (FLANŞLI 180°)	CASING (w/ 180° FLANGED PORTS)	1
4	BİLEZİK	SPACER	1	20	ÇEVRE DİŞLİ	ROTOR GEAR	1
5	AYAR SOMUNU	ADJUSTING NUT	2	21	AVARA DİŞLİ	IDLER GEAR	1
6	KEÇE $\phi 55 \times \phi 72 \times 10$	LIP SEAL $\phi 55 \times \phi 72 \times 10$	1	22	AVARA DİŞLİ BURCU	IDLER BUSHING	1
7	RULMAN (3209)	BALL BEARING (3209)	1	23	KAPAK MİLİ	COVER PIN	1
8	KEÇE $\phi 50 \times \phi 72 \times 10$	LIP SEAL $\phi 50 \times \phi 72 \times 10$	1	24	KAPAK MİLİ	JACKETD COVER PIN	1
9	İÇ SEGMAN ($\phi 90$)	INTERNAL CIRCLIP ($\phi 90$)	2	25	KAPAK (KÖR ve BYPASSLI)	COVER	1
9.1	İÇ SEGMAN ($\phi 70$)	INTERNAL CIRCLIP ($\phi 70$)	2	26	KAPAK (CEKETLİ)	JACKETD COVER	1
10	KEÇE $\phi 50 \times \phi 70 \times 10$	LIP SEAL $\phi 50 \times \phi 70 \times 10$	5	27	BYPASS CONTASI	BYPASS GASKET	2
10.1	KEÇE $\phi 50 \times \phi 90 \times 10$	LIP SEAL $\phi 50 \times \phi 90 \times 10$	1	28	BYPASS KÖR KAPAK	BYPASS INLETS COVER	2
11	RULMAN(3210)	BALL BEARING(3210)	1	29	6 KÖŞE CIVATA M10x30	HEX BOLT M10x30	8
12	MİL	SHAFT	1	30	GRESÖR R3/8"	GREASING FITTING R3/8"	1
13	KAMA 12x8x45 A	ROTOR KEY 12x8x45 A	1	31	SETUSKUR M12x16	GRUB SCREW M12x16	4
14	6 KÖŞE CIVATA M16x40	HEX BOLT M16x40	16	32	KONSOL (CEKETLİ)	BRACKET (w/ HEATING JACKET)	1
15	KONSOL	BRACKET	1				
16	KONSOL & KAPAK CONTASI	BRACKET & COVER GASKET	2				

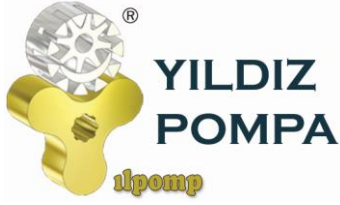

YKF 4" POMPA INTERNAL ECCENTRIC GEAR PUMP



YEDEK PARÇA LİSTESİ / SPARE PARTS LIST

KARTEXLİ VE BYPASSLI / SEALED WITH CARTEX MECHANICAL SEAL, AND PRESSURE RELIEF VALVE ON COVER

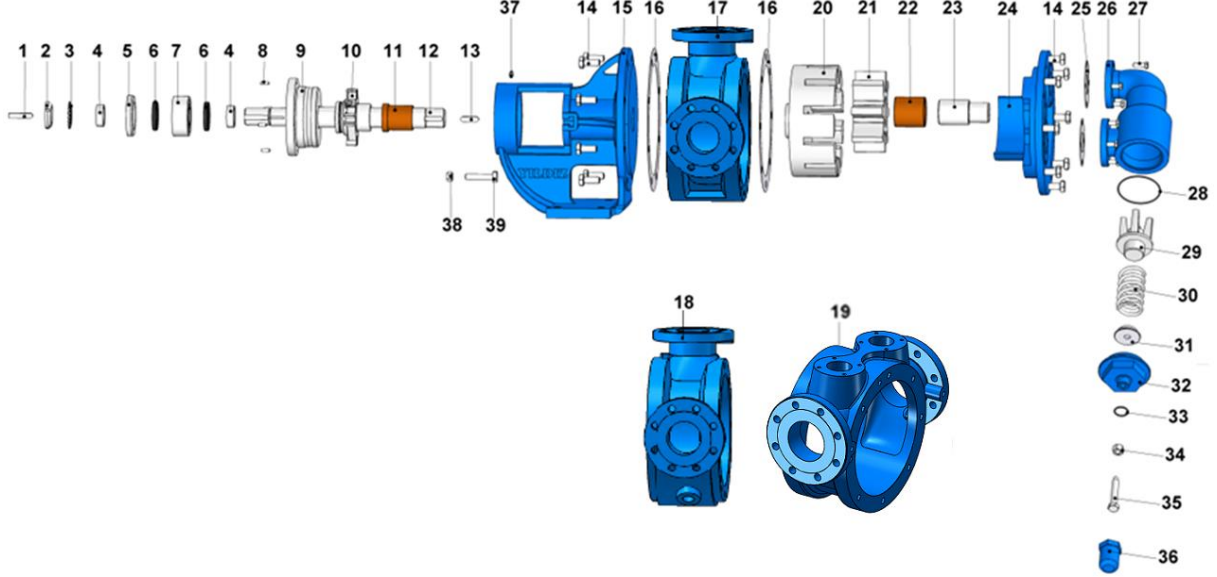

No	PARÇA İSMİ	PART NAME	ADET/ QTY.	No	PARÇA İSMİ	PART NAME	ADET/ QTY.
1	KAMA 12x8x60 AB	COUPLING KEY 12x8x60 AB	1	21	AVARA DİŞLİ	IDLER GEAR	1
2	KİLİT SOMUNU	LOCK NUT	1	22	AVARA DİŞLİ BURCU	IDLER BUSHING	1
3	KİLİT SACI	LOCK WASHER	1	23	KAPAK MİLİ	COVER PIN	1
4	BİLEZİK	SPACER	2	24	KAPAK (KÖR ve BYPASSLI)	COVER	1
5	TAMBUR KAPAKĞI	PULLEY COVER	1	25	BYPASS CONTASI	BYPASS GASKET	2
6	KEÇE $\phi 55 \times \phi 72 \times 10$	LIP SEAL $\phi 55 \times \phi 72 \times 10$	2	26	BYPASS	PRESSURE RELIEF VALVE - BYPASS	1
7	RULMAN (3209)	BALL BEARING (3209)	1	27	6 KÖŞE CİVATA M10x30	HEX BOLT M10x30	8
8	SETUSKUR M8x20	GRUB SCREW M8x20	4	28	BYPASS O-RING	BYPASS O-RING	1
9	TAMBUR	PULLEY	1	29	KLEPE	VALVE	1
10	CARTEX MEKANİK SALMASTRA $\phi 50$	CARTEX MECHANICAL SEAL $\phi 50$	1	30	YAY	SPRING	1
11	KONSOL BURCU	BRACKET BUSHING	1	31	PUL	WASHER	1
12	MİL	SHAFT	1	32	BYPASS KAPAĞI	BYPASS COVER	1
13	KAMA 12x8x45 A	ROTOR KEY 12x8x45 A	1	33	TIJ KAPAK O-RİNG	CAP O-RING	1
14	6 KÖŞE CİVATA M16x40	HEX BOLT M16x40	16	34	M16 SOMUN	NUT M16	1
15	CARTEXLİ KONSOL	BRACKET (w/ CARTEX MECH. SEAL)	1	35	6 KÖŞE CİVATA M16x70	ADJUSTING SCREW M16x70	1
16	KONSOL & KAPAK CONTASI	BRACKET & COVER GASKET	2	36	TIJ KAPAĞI	CAP	1
17	ARA GÖVDE (FLANŞLI 90°)	CASING (w/ 90° FLANGED PORTS)	1	37	GRESÖR R3/8"	GREASING FITTING R3/8"	1
18	ARA GÖVDE (FLANŞLI CEKETLİ 90°)	CASING (90° FLANGED & w/ HEATING JACKET)	1	38	M16 SOMUN	NUT M16	2
19	ARA GÖVDE (FLANŞLI 180°)	CASING (w/ 180° FLANGED PORTS)	1	39	4 KÖŞE SALMASTRA BASKI CİVATASI M16x90	SQUARE SCREW M16x90	2
20	ÇEVRE DİŞLİ	ROTOR GEAR	1				



YK4 4" POMPA INTERNAL ECCENTRIC GEAR PUMP



YEDEK PARÇA LİSTESİ / SPARE PARTS LIST

KARTEKLİ VE CEKETLİ KÖR KAPAKLI / SEALED WITH CARTEX MECHANICAL SEAL, JACKETED AND WITH BLIND COVER

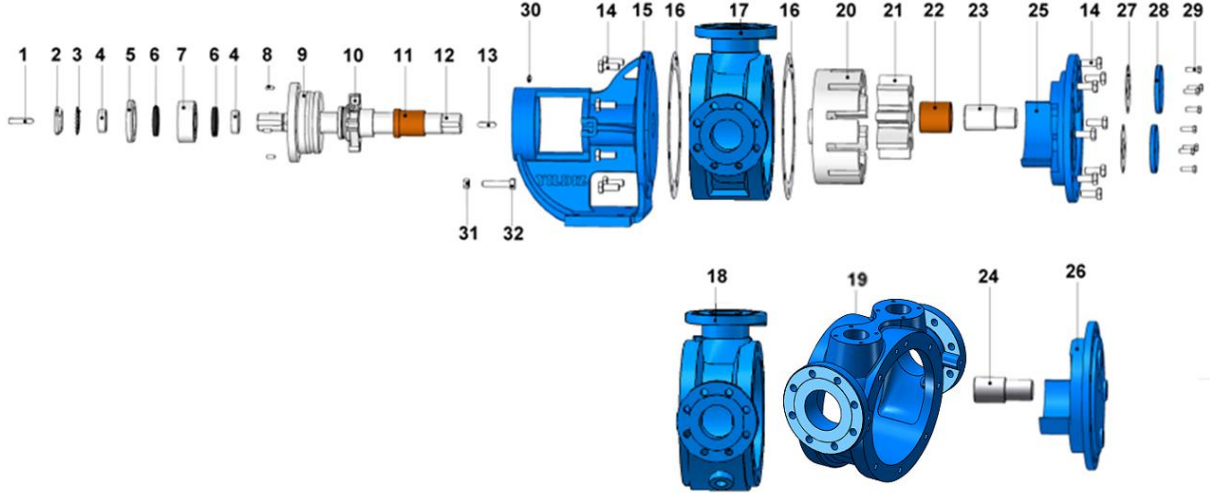

No	PARÇA İSMİ	PART NAME	ADET/ QTY.	No	PARÇA İSMİ	PART NAME	ADET/ QTY.
1	KAMA 12x8x60 AB	COUPLING KEY 12x8x60 AB	1	17	ARA GÖVDE (FLANŞLI 90°)	CASING (w/ 90° FLANGED PORTS)	1
2	KİLİT SOMUNU	LOCK NUT	1	18	ARA GÖVDE (FLANŞLI CEKETLİ 90°)	CASING (90° FLANGED & w/ HEATING JACKET)	1
3	KİLİT SACI	LOCK WASHER	1	19	ARA GÖVDE (FLANŞLI 180°)	CASING (w/ 180° FLANGED PORTS)	1
4	BİLEZİK	SPACER	2	20	ÇEVRE DİŞLİ	ROTOR GEAR	1
5	TAMBUR KAPAKĞI	PULLEY COVER	1	21	AVARA DİŞLİ	IDLER GEAR	1
6	KEÇE Ø55xØ72x10	LIP SEAL Ø55xØ72x10	2	22	AVARA DİŞLİ BURCU	IDLER BUSHING	1
7	RULMAN (3209)	BALL BEARING (3209)	1	23	KAPAK MİLİ	COVER PIN	1
8	SETUSKUR M8x20	GRUB SCREW M8x20	4	24	CEKETLİ KAPAK MİLİ	JACKETD COVER PIN	1
9	TAMBUR	PULLEY	1	25	KAPAK (KÖR ve BYPASSLI)	COVER	1
10	CARTEX MEKANİK SALMASTRA Ø50	CARTEX MECHANICAL SEAL Ø50	1	26	KAPAK (CEKETLİ)	JACKETD COVER	1
11	KONSOL BURCU	BRACKET BUSHING	1	27	BYPASS CONTASI	BYPASS GASKET	2
12	MİL	SHAFT	1	28	BYPASS KÖR KAPAK	BYPASS INLETS COVER	2
13	KAMA 12x8x45 A	ROTOR KEY 12x8x45 A	1	29	6 KÖŞE CİVATA M10x30	HEX BOLT M10x30	8
14	6 KÖŞE CİVATA M16x40	HEX BOLT M16x40	16	30	GRESÖR R3/8"	GREASING FITTING R3/8"	1
15	CARTEKLİ KONSOL	BRACKET (w/ CARTEX MECH. SEAL)	1	31	M16 SOMUN	NUT M16	2
16	KONSOL & KAPAK CONTASI	BRACKET & COVER GASKET	2	32	4 KÖŞE SALMASTRA BASKI CİVATASI M16x90	SQUARE SCREW M16x90	2