

POMPA DEĞERLERİ /
PUMP PROPERTIES

Q	:1,4 m ³ /h
Hm	:1 ~ 30 Bar
T	:0 ~ 100 °C
n	:1 ~ 1500 d/d
Visc.	:10 ~ 550 cst



KULLANIM ALANLARI

- Fuel Oil Servis Tankları, Gaz Yağı, Mazot Tankerlerinde
- Küçük çapta kızgın yağ sirkülasyonlarında
- Endüstrinin yarı viskoz mayilerinin pompaj işlemlerinde
- Boya Sanayinde
- Gemi Sektörü

MALZEME SEÇENEKLERİ

- Pompa Gövdesi ve Kapaklar:Dökme (pik) demir,çelik döküm, paslanmaz AISI 316/316L döküm, sfero döküm
- Dişliler:Çelik, paslanmaz çelik AISI 316/316L
- Yataklar:Snbz 12 bronz, rulman, karbon grafit, ina burç
- Sızdırmazlık: Yumuşak salmastra, mekanik salmastra,keçe

USE AREAS

- Fuel Oil Service Tanks, Gas Oil, Diesel-fuel Tanks
- On a small scale hot oil circulations
- Half viscose liquids of industry are on pumping process
- Dye Industry
- Ship Sector

MATERIAL OPTIONS

- Pump Body and covers: Cast iron, steel cast, stainless AISI 316/316L cast
- Gears: Steel, stainless steel AISI 316/316L
- Bearings: Snbz 12 bronz, bearing, carbon graphite, Ina bushing bearing
- Sealing: Soft seal, mechanical seal, lip seal

H2C POMPASINA AİT KAPASİTE VE GÜÇ TABLOSU CAPACITY AND POWER TABLE								
KAPASİTE(m ³ /h) CAPACITY (Q)	DEVİR (d/d) SPEED (rpm)	ÇIKIŞ BASINCI / PRESSURE						VİSKOZİTE VISCOSITY
		5 Bar	10 Bar	15 Bar	20 Bar	25 Bar	30 Bar	
0,46	500	0.55 kW	0.75 kW	1.1 kW	1.1 kW	1.5 kW	1.5 kW	550 cst
0,92	1000	0.75 kW	1.1 kW	1.5 kW	1.5 kW	2.2 kW	2.2 kW	550 cst
0,46	500	0.37 kW	0.55 kW	0.75 kW	0.75 kW	1.1 kW	1.1 kW	165 cst
0,93	1000	0.55 kW	0.75 kW	1.1 kW	1.1 kW	1.5 kW	1.5 kW	165 cst
1,4	1500	0.75 kW	1.1 kW	1.5 kW	1.5 kW	2.2 kW	2.2 kW	165 cst
0,65	700	0.37 kW	0.55 kW	0.75 kW	0.75 kW	1.1 kW	1.1 kW	22 cst
0,93	1000	0.55 kW	0.75 kW	1.1 kW	1.1 kW	1.5 kW	1.5 kW	22 cst
1,4	1500	0.75 kW	1.1 kW	1.5 kW	1.5 kW	2.2 kW	2.2 kW	22 cst

Tabloda bulunan veriler standart viskozitelere göre hazırlanmıştır. Tabloda bulunmayan viskozite değerleriniz için lütfen firma ile iletişime geçiniz.

The data in the table are prepared according to standard viscosities. Please contact the company for viscosity values not included in the table.

POMPA BOYUT ÖLÇÜLERİ / PUMP DIMENSIONS

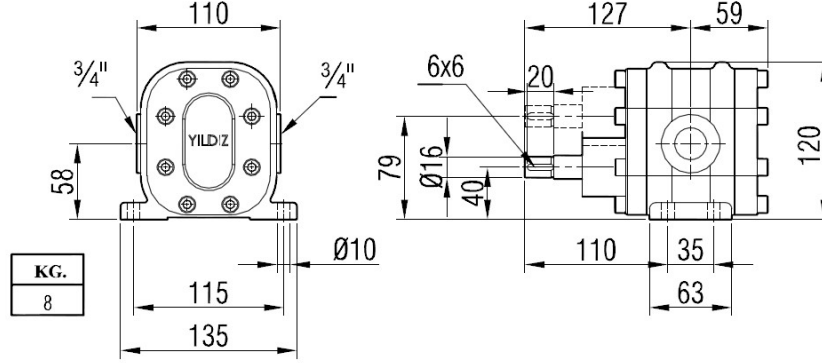

Paslanmaz ve exproof durumunda ölçülerin değişim hakkı firmamızda saklıdır. Bilgi için lütfen firma ile iletişime geçiniz.

When it is stainless and exproof, our company reserves the right to change the measurement. For more information, please contact the company.

AKUPLAJ ÖLÇÜLERİ / COUPLING DIMENSIONS

- **REDÜKTÖR AKUPLİLELİ**
GEARBOX DRIVE

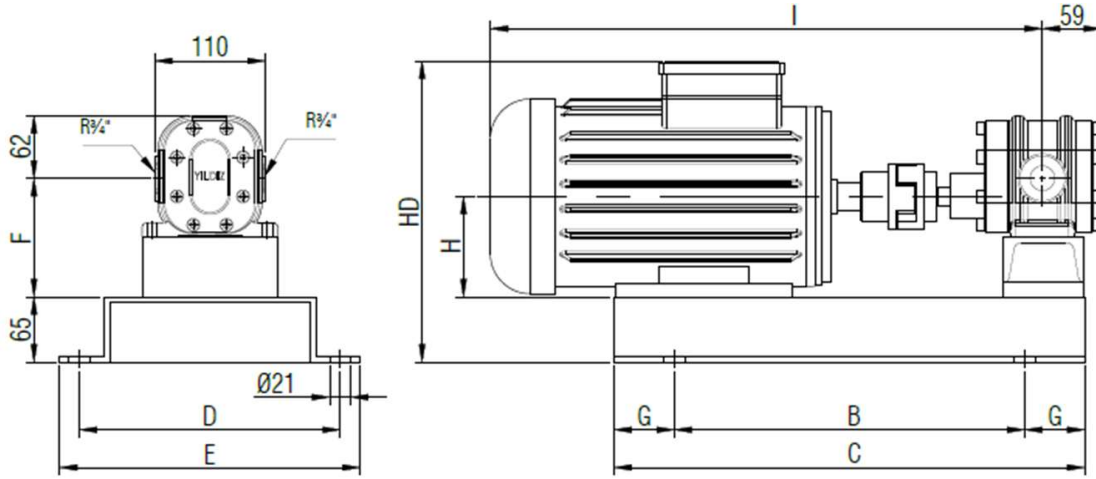

MOTOR GÜÇ VE DEVİRLERİ / MOTOR POWER AND SPEED			I	HD	H	B	C	D	E	F	G	kg.	
1 hp /0,75 kW	1500 d/d(rpm)	MOTOR 80	423	263	78	300	420			98		27	28
0,5 hp / 0,37 kW	750 d/d(rpm)	MOTOR 90S	454	281	88	350	470	260	300	108	60	31	
1 hp /0,75 kW	1000d/d(rpm)												
1,5 hp /1,1 kW	1500 d/d(rpm)	MOTOR 90L	505									33	
1 hp /0,55 kW	750 d/d(rpm)												
1,5 hp /1,1 kW	1000d/d(rpm)												
2 hp /1,5 kW	1500 d/d(rpm)	MOTOR 100L	552	289	97	380	500	260	300		60	34	
1-1,5 hp /0,75-1,1 kW	750 d/d(rpm)												
2 hp /1,5 kW	1000d/d(rpm)												
3-4 hp /2,2-3 kW	1500 d/d(rpm)												

YEDEK PARÇA LİSTESİ / SPARE PARTS LIST

• **KEÇELİ**
LIP SEAL

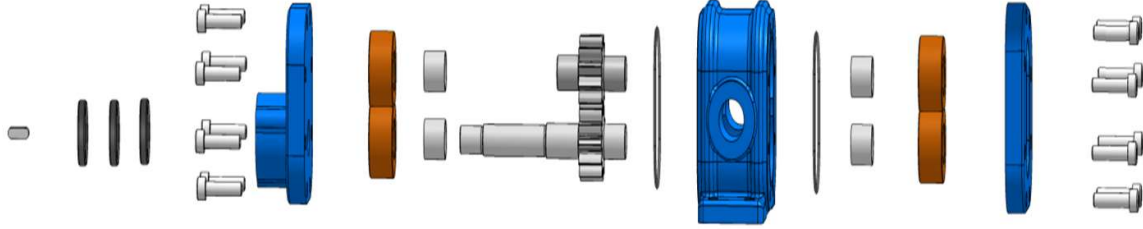

• **MEKANİK SALMASTRALI**
SEALED WITH MECHANICAL SEAL

